

Self Centering Vise 5 AXIS VISE



NEW

VCV-1090

- Suit for 4/5 axis CNC machine
- Repeat clamping tolerance $\pm 0.01\text{mm}$
- Material: FCD60, high tenison cast iron
Slide way hardness: HRC 45°
- Inter changeable jaw: heat treatment HRC 55°
- Lock down-drawing force: keep work piece from lifting



VCV-0611

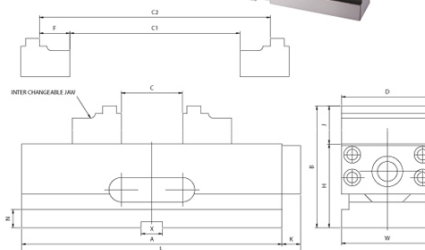

Specifications

Unit:mm

ORDER NO.	A	B	C OPEN	CLAMPING CAPACITY			D	E	F	H	J	K	N	X	L	CODE NO.
				C1	C2	C3										
VCV-0611	170	80	109	110	110-150		60		20	55	25	15	14	14	185	1002-107
VCV-1090	240	120	90	90	70-160	134-222	100	31	35	80	40	20	22	18	260	1002-108

U/N Work Stopper



NON TEETH TYPE
ORDER NO. VWS-123
CODE NO. 1002-105
WEIGHT: 0.9kg
T-SLOT: 16mm

ORDER NO. VWS-125
CODE NO. 1002-106
WEIGHT: 1.1kg
T-SLOT: 16mm

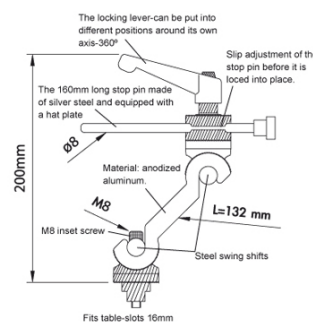
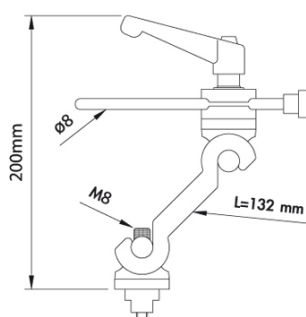

- It is fixed and secured by its rigid serration without skid. (300kg bump is permanent)

Universal Vise Jaws With Work Stopper



ORDER NO. VWSJ-4, 5, 6, 8

- Can be fixed on any vise jaw by the two screws on the side.
- One jaw in multiple- function features.
- V-type jaw can fix workpiece at horizontal and vertical position.
- Can be performed as work stopper.
- Quick, save your time.

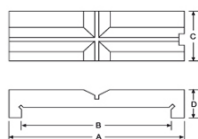

4 FOR THE JAW WIDTH 100-110m/m
5 FOR THE JAW WIDTH 125-140m/m
6 FOR THE JAW WIDTH 150-160m/m
8 FOR THE JAW WIDTH 200-210m/m



ORDER NO.
VWSJ-□ — VISE JAW SIZE
(Unit:inch)

Unit:mm

ORDER NO.	A	B	C	D	WEIGHT kgs	CODE NO.
VWSJ-4	145	110	49	38	1.6	1002-170
VWSJ-5	175	140	49	39	1.7	1002-171
VWSJ-6	190	160	53	40	2	1002-172
VWSJ-8	245	210	76	42	4.2	1002-173