

## MC Power Vise



**TOGGLE JOINT MECHANISM  
DESIGN FOR HEAVY DUTY  
WORKING**

### Features

- Compact design. Great clamping capacity & rigid.
- "Toggle joint mechanism". Provides a steady clamping force against shocks and vibrations during the operations, since it clamps the workpiece resiliently with an aid of the "disc-springs" mounted inside.
- Strong clamping force.
- Large jaw stroke range.
- Exclusive Power Vise provide same height same position for horizontal and vertical MC, NC, Machine.
- Body is made of FCD60 high quality ductile cast iron, resists deflection or bending.
- Sliding bed ways flame hardened and ground.
- Concealed spindle for protection against chips and dirt.
- Quick of clamping & locking and easy of operation.

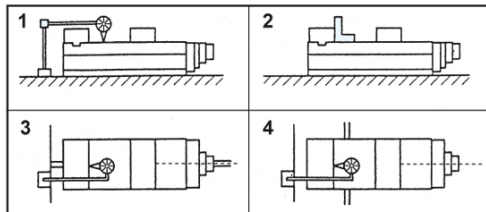

### INSPECTION SPECIFICATION

NO.	Inspection Item	Per (100mm)	Guaranteed
1	Parallelism: running face to bottom of bed.		0.01/100mm
2	Squareness :between running face and jaw plate.		0.02/100mm
3	Squareness: keways on bottom of bed to jaw plate.		0.02/100mm
4	Parallelism: running face of the test block to bottom of bed.		0.02/100mm

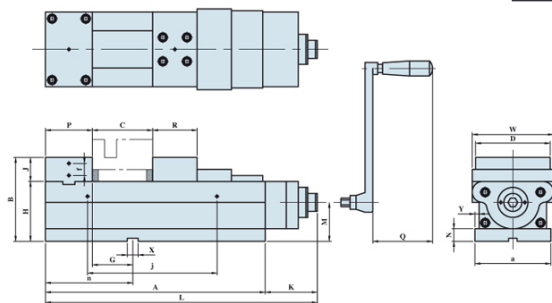

### CLAMPING CAPACITY

ORDER NO.	JAW H	JAW Open C	H	MAX. Clamping Force (KN)	G.W. kg
VQC-100	35	128	120	30	16.84
VQC-125	40	205	140	40	40.4
VQC-160	45	275	165	60	72.3
VQC-160L	45	355	165	60	78.6
VQC-200L	70	405	190	60	108

ORDER NO.	A	B	a	D	P	R	G	H	J	K	L
VQC-100	273	120	105	99	73	64	39	85	35	82.5	356.5
VQC-125	366	140	126	124.5	78	74	66	100	40	86	452
VQC-160	456	165	161	159.5	86	86	58	120	45	98	554
VQC-160L	536	160	162	160	86	86	58	115	45	98	634
VQC-200L	616	180	202	200	102	98	74	120	70	95	711

ORDER NO.	M	N	Q	W	X	Y	C OPEN	f	j	n	CODE NO.
VQC-100	50	15	74	110	14	6.5	128	20	105	112	4005-004
VQC-125	65	21	74	135	18	7	205	20	216	145	4005-005
VQC-160	78	21	94	170	18	7	275	20	286	145	4005-006
VQC-160L	78	21	94	174	18	7	355	20	286	145	4005-007
VQC-200L	75	21	96	217	18	7	405	20	386	177	4005-008