

## 3-Way Angle Milling Vise

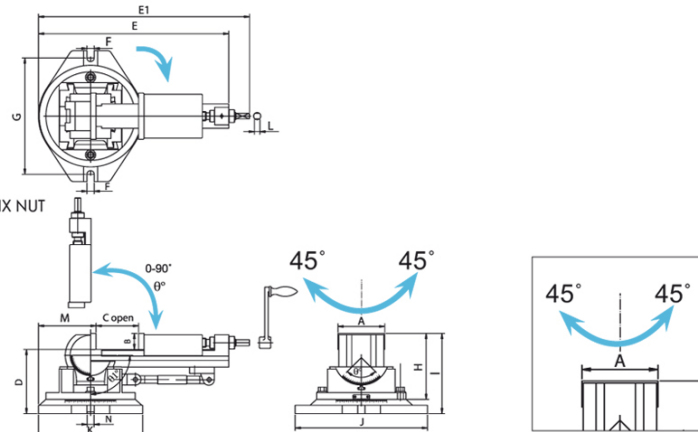

ANGLE MILLING VISE

- Angles can be set in 3 dimensions. Swivels 360° around base. The vise can be elevated through 90° from the horizontal to vertical. And also can be tilted on its lower angle base up to 45° in both right and left.
- Tilting of any angle all keep the workpiece steady, smooth.
- Particularly the clamping part of screw is strengthened by a bush made of gunmetal.
- Turn ① to adjust tilting angle. fix ② to lock.

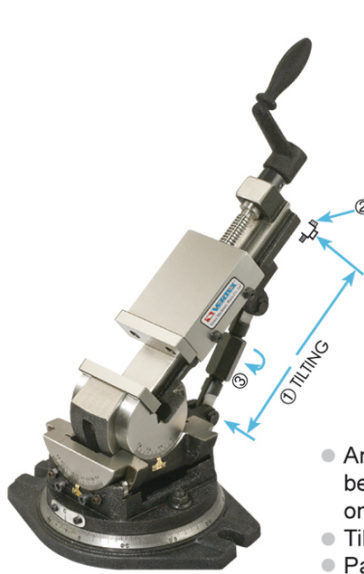

### Specifications

ORDER NO.	A	B	C OPEN	D	E	E1	F	G	H	I	J	K	L	M	N	$\theta$	$\theta_1$	MAX. Clamp Force (kgf)	G.W. (kgs)	Meas CFT	CODE NO.
VW-3	80	31	85	126	335	370	15	210	127	157	240	185	10	95	16	-45°~45°	-0°~90°	800	16.7	40x21x19	1002-080
VW-4	110	38	116	152	448	497	17	276	157	190	311	245	13	135	16	-45°~45°	-0°~90°	1000	32.7	56x27x23	1002-081
VW-5	135	40	145	170	530	580	17	310	173	210	358	271	13	140	16	-45°~45°	-0°~90°	1600	49.4	66x31x25	1002-082

## Quick Index Holder

### VFV-40H

- SHANK HEX. TYPE
- FOR CUTTING 6 DIVISION TYPE
- EACH 60° FOR 1 DIVISION
- ※ FOR CUTTING HEX. & SQUARE SHAPE ON ROUND BAR & ROD
- ※ THROUGH HOLE

NEW



### VFV-41S

- SHANK SQUARE TYPE
- FOR CUTTING 4 DIVISION
- EACH 90° FOR 1 DIVISION

patent PAT.



60° DIVIDING FOR PUT ON THE VISE

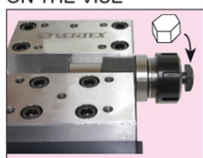

HORIZONTAL

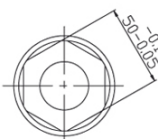

90° DIVIDING FOR PUT ON THE VISE



VERTICAL

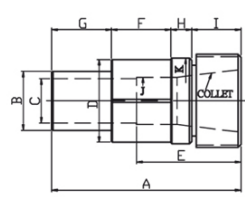

mm

ORDER NO.	A	B	C	D	E	F	G	H	I	J	K	COLLET SIZE	WEIGHT KGS	CODE NO.
VFV-40H	127	40	30	56	70	40	40	14	33	32	58	ER-40 7 PCS/SET	4.8	1001-101
VFV-41S	127	40	30	56	70	40	40	14	33	32	58	ER-40 7 PCS/SET	5.2	1001-102