

Horizontal / Vertical Rotary Table

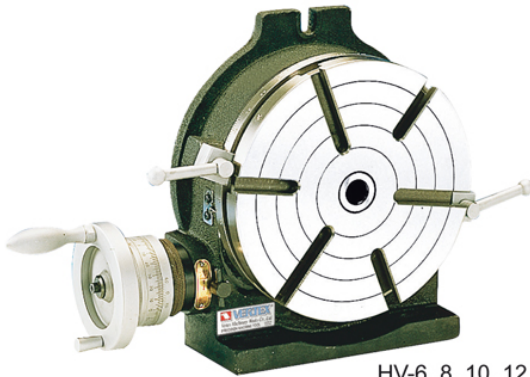

HV-6, 8, 10, 12, 14, 16



HV-4

Special Accessories (Details on page 2)

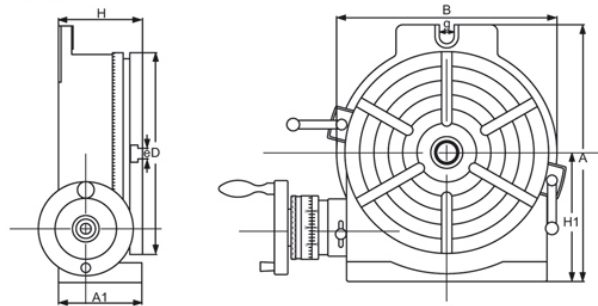
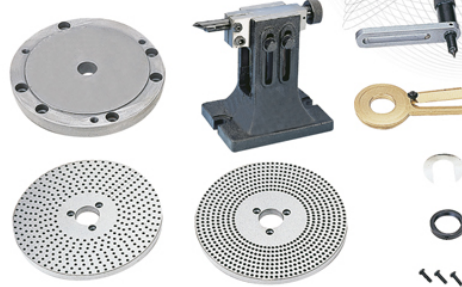

Specifications

ORDER NO.	Table			Base dimension			Width of T-soft	Bolt slots	The Load Capacity For Rotary Table		Center sleeve	Gross Weight(kg)		Meas. CFT	CODE NO.	
	Outer diameter	Height							Horizontal	Vertical		wooden case(W)	Carton(C)			
	A1	D	H	H1	A	B	e	Type	g			N.W.	G.W.			
HV-4	58	110	72	80	138	118	11	⊕		35 KGS	18 KGS	MT-2	7KGS	7.5KGS (C)	0.3	1001-000
HV-6	78	150	80	102	205	163	11	⊕	17	40 KGS	20 KGS	MT-2	12.1KGS	12.7KGS (C)	0.4	1001-001
HV-8	100	205	102	135	265	219	14	⊕	17	80 KGS	40 KGS	MT-3	24.7KGS	26.2KGS (C)	0.8	1001-002
HV-10	106	254	109	163	321	276	14	⊗	17	90 KGS	50 KGS	MT-3	35.5KGS	37.3KGS (C)	2	1001-003
HV-12	123	305	125	194	388	330	16	⊗	18	120 KGS	60 KGS	MT-4	58.7KGS	69.8KGS (W)	2.6	1001-004
HV-14	123	353	125	225	445	389	16	⊗	18	130 KGS	70 KGS	MT-4	76.61KGS	90.3KGS (W)	3.2	1001-005
HV-16	128	406	130	258	503	435	16	⊗	18	140 KGS	70 KGS	MT-4	106.4KGS	123.1KGS (W)	4.2	1001-006

Umit:mm/inches

- Our Tables are made of high density Meehanite and use "HEIDENHAIN" electronic equipment to inspect angle to assure the excellent quality and durability.
- Use excellent machining center to process. Spindle end be applied accuracy bearing. Can be assured to keep very steady under load cutting.
- Worm is hardened and ground. The ratio is 90:1. The work table is graduated a full 360° so that one turn of the handle moves the table through 4°. Micro collar is graduated in steps of 1' min. And vernier scale makes settings down to 10 seconds possible.
- These Rotary Tables are popular for their excellent performance, practical design and reasonable cost. They are widely used for circular cutting work, angle setting, boring, spot-facing and similar work.
- Indexing accuracy of direct Indexing mechanism Maximum cumulative spacing error 1 minute.
- Please choose Front-Lock 3 Jaw chuck only.

3-Jaw Chuck For Rotary Table, Indexer

- Detail specification & Order NO. shown on page E6



ORDER NO.

- VSC-5A SUIT FOR BS-0 OR HV-6, VUT-6, VU-150
- VSC-6A SUIT FOR BS-1 OR HV-8, 10, VUT-6, VU-200
- VSC-7A, 8A SUIT FOR BS-2 OR HV-10, 12, 14, VUT-10, 12
- VSC-10A SUIT FOR HV-14, 16

Reversible type For indexer, The fixing hole is from front.



ORDER NO.

- VSK-6A SUIT FOR CS-6, CC-6
- VSK-8A SUIT FOR CS-8, CC-8
- VSK-12A SUIT FOR CC-12