

COPA MANDRIL MANUAL INDEPENDIENTE DE 4 MORDAZAS 3-855-0800P



Selling Unit		EA
Chuck Type		Independent
Chuck Size	in	8
Body Material		Forged Steel
Number of Jaws		4
Jaw Type		2pc
Weight	lb	38
Mount Type		Front
Max RPM	RPM	2500

DIAMETRO 8" 200MM

Diameter D	in	7.878
Recess Diameter B	in	4.3307
Recess Depth C	in	0.1969
Hole Diameter E	in	1.9685
Bolt Circle Diameter F	in	3.252
Body Height H	in	2.8543
Jaw Height H1 (Two-piece Jaws)	in	1.8268
Hole Thread Size S		4xM10

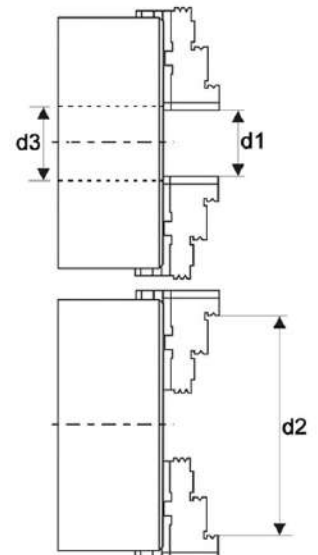
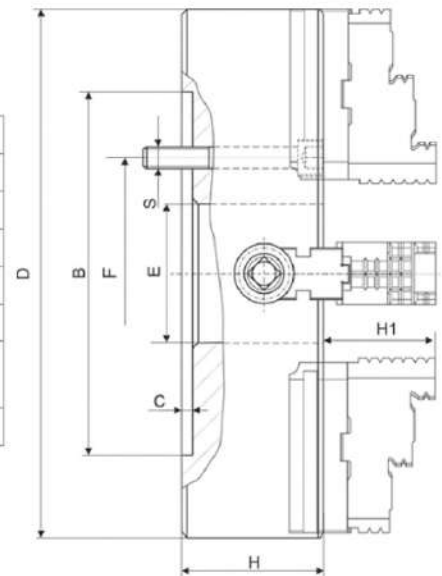

d1 Min	in	0.394
d2 Max	in	7.874
Chuck Thru Hole d3	in	1.9689