

COPA MANDRIL MANUAL INDEPENDIENTE DE 4 MORDAZAS 3-855-1600P



| | | |
|----------------|-----|--------------|
| Selling Unit | | EA |
| Chuck Type | | Independent |
| Chuck Size | in | 16 |
| Body Material | | Forged Steel |
| Number of Jaws | | 4 |
| Jaw Type | | 2pc |
| Weight | lb | 189 |
| Mount Type | | Front |
| Max RPM | RPM | 1100 |

DIAMETRO 16" 400MM

| | | |
|--------------------------------|----|--------|
| Diameter D | in | 15.748 |
| Recess Diameter B | in | 7.874 |
| Recess Depth C | in | 0.3937 |
| Hole Diameter E | in | 3.937 |
| Bolt Circle Diameter F | in | 6.748 |
| Body Height H | in | 3.622 |
| Jaw Height H1 (Two-piece Jaws) | in | 2.8465 |
| Hole Thread Size S | | 4xM16 |

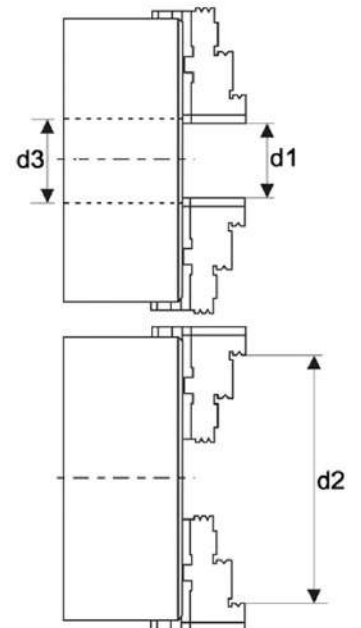
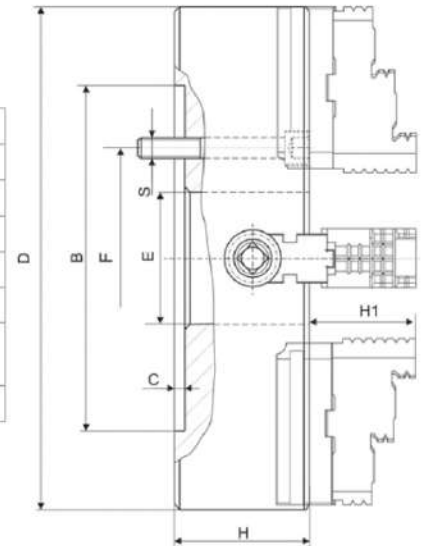

| | | |
|--------------------|----|--------|
| d1 Min | in | 0.787 |
| d2 Max | in | 15.748 |
| Chuck Thru Hole d3 | in | 3.937 |

